Naviglio

SOFAS

2020

Yabu Pushelberg



Description

A visual dialogue between structure and shapes, the Naviglio seating collection is made up of curved, linear and terminal elements, chaise longues, and ottomans. Synthesis is the project's essence and starts from its name. The seating base is a riverbed that defines the space to accommodate a backrest/armrest which is as sinuous as a watercourse. As a piece of a puzzle, each shape is ergonomically designed into a single cohesive unit. The backrest section and the seating reveal a delicate balance between polygons and curved shapes, where geometry becomes softness and rigour blends with comfort. The different elements' upholstery is made of flexible polyurethane, to welcome and correctly support the body. The choice was dictated by the object's nature – a sofa without seat cushions. The covers are available in a wide range of fabrics and shades. The backrest back features a continuous decorative insert, providing a linear element that further emphasizes the shape's continuity.

Technical information

Internal frame

tubular steel and steel profiles

Internal frame upholstery

Bayfit® flexible cold shaped polyurethane foam, polyester fibre cover

Armrest cushion (NA60_B)

visco-elastic polyurethane, cover in polyester fibre and cotton, counterweight in lead chips

Feet

thermoplastic material

Top (TNA40)

glass

Support frame (TNA40)

steel

Base-frame (TNA40)

marble (matt polyester finish)

Cover

fabric (decorative section in Bellano fabric)

Technical drawings

NA95C

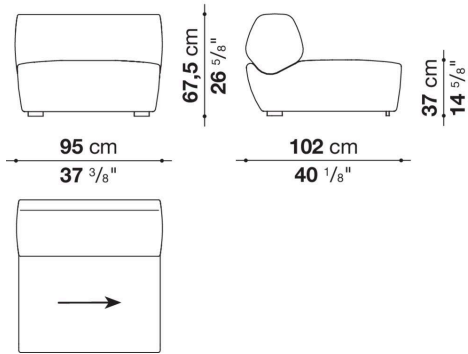

NA143C

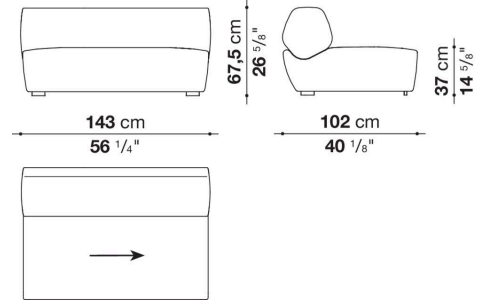

NA190C

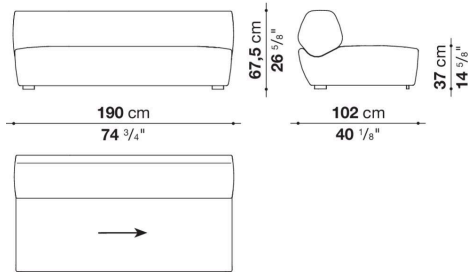

NA143TS

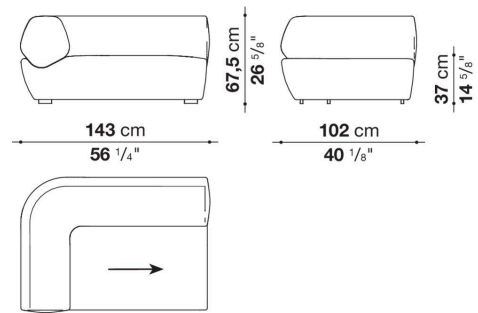

NA143TD

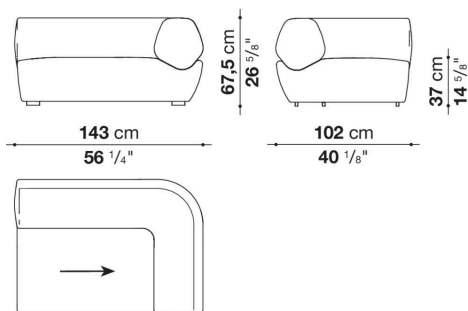

NA188TS

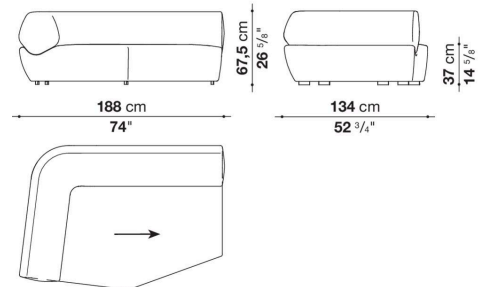

NA188TD

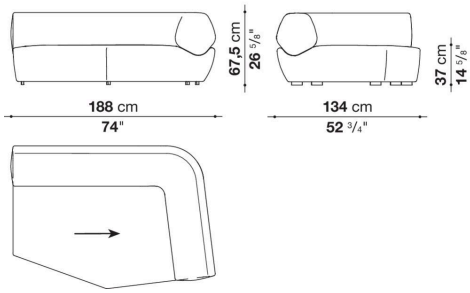

NA102AS

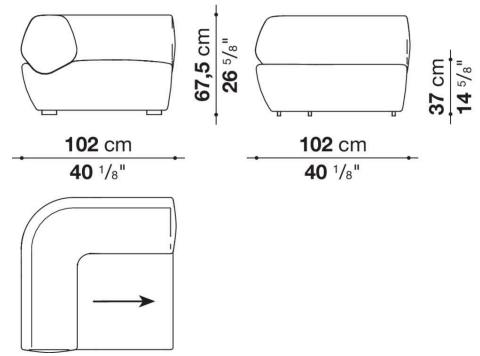

NA102AD

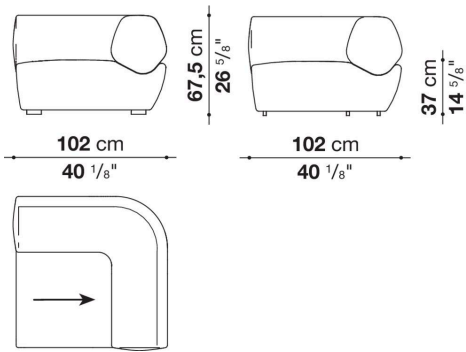

NA217A

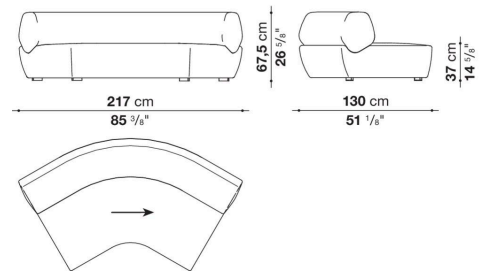

NA185LS

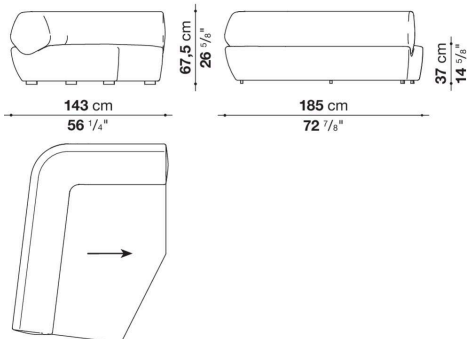

NA185LD

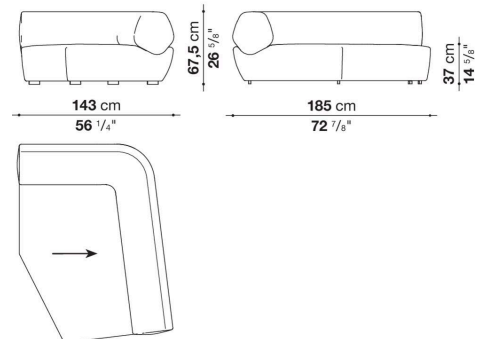

NA102PS

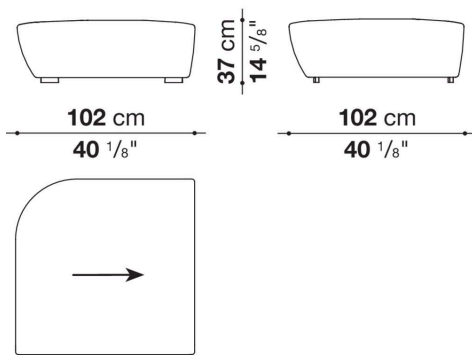

NA102PD

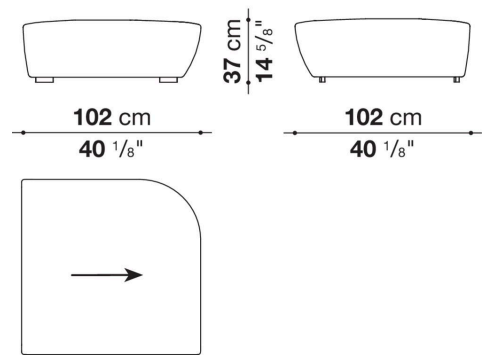

TNA40

