

Nonaro (Azucena)

CHAIRS

1959



AZUCENA
The Nonaro family is part of the Azucena collection

Description

Luigi Caccia Dominioni designed the Nonaro chairs specifically for visitors to the Pinacoteca Ambrosiana in Milan who wanted to sit and gaze at Raphael's Cartoon for the School of Athens, one of the museum's prize possessions. In marrying art with design, Caccia Dominioni borrowed from classic Italian garden decor, frescoes from ancient Rome and Renaissance painting. The result is a sophisticated harmony of curves that define the seating system with its delicate armrests and legs. But he was also inspired by memories of a garden chair in the 18th century family Villa Il Nonaro in Varese. Nonaro today is a collection of garden furniture with generously upholstered cushions for maximum comfort. Here we have an authentic contemporary classic, perfect for admiring the surrounding beauty, and that for decades has graced the grandest gardens and terraces around the world.

Technical information

Frame and mesh

painted metal

Upholstery

shaped polyurethane, cover in water repellent polyester fibre

Ferrules

plastic material

Cover

fabric in limited categories

Technical drawings

ON4

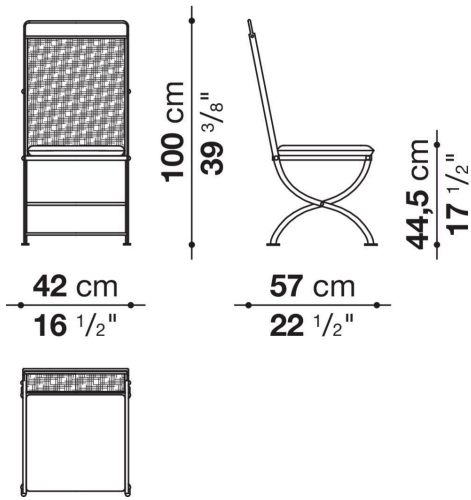

ON5

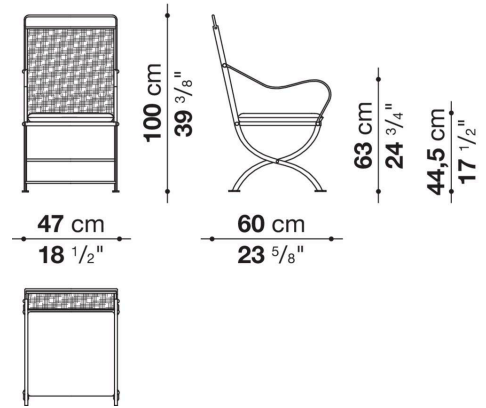

ON3

