Erica modular

SOFAS

2025

Antonio Citterio



Description

Sophisticated design and versatility come together in the Erica '25 seating system in the modular version, a proposal that adapts perfectly to different needs and spaces, offering high design freedom. Central, terminal and corner elements in different sizes allow to interpret the outdoor space in a very personal way thanks to the system flexibility and the wide range of finishings offered for the frames and the interlacing, complemented by a vast range of covers, in an array of tones and designs, all co-ordinating with each other. The modular version incorporates the characteristic elements of the entire Erica '25 series: the powder-coated die-cast aluminium frame which offer lightness and durability, the interlacing made of polypropylene ribbons designed for outdoor use, and the foot design which provides a sense of visual and formal continuity. The seat cushions upholstery, embellished with a decorative profile, grants an appearance of natural softness making them particularly inviting. The lightness and refined design make Erica '25 ideal for both public and residential settings, delivering ergonomic comfort together with strength for outdoor use.

Technical information

Frame

die-cast aluminium and extrusions with polyester powder painting

Back upholstery

polyester fiber recycled from PET, cover in water repellent polyester fibre

Seat upholstery

shaped polyurethane, polyester fiber recycled from PET, cover in water repellent polyester fibre

Seat slats

polypropylene and glass fibre

Interlacing

polypropylene fibre braid

Ferrules

thermoplastic material

Waterproof cover cloth

PES fabric coated on one side in PU

Cover

fabric in limited categories (with profile)

Technical drawings

CE230

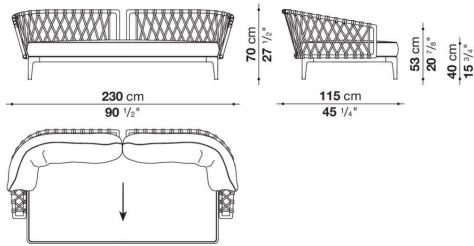

CE131C

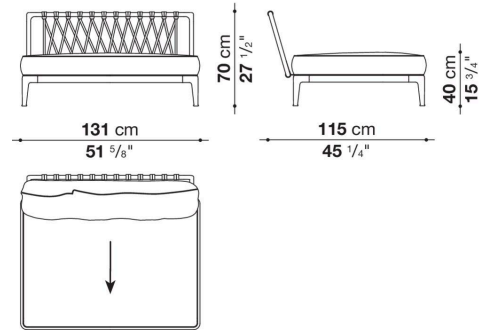

CE191C

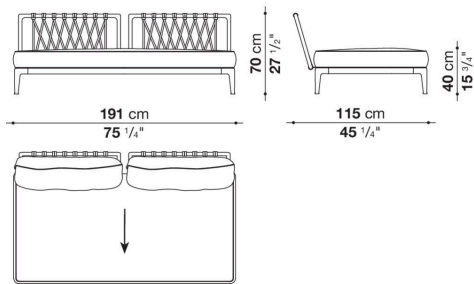

CE150S

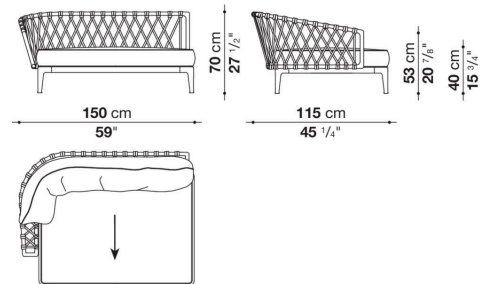

CE150D

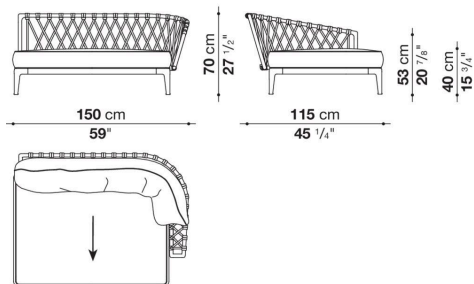

CE210S

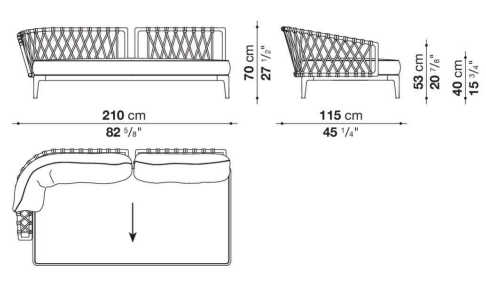

CE210D

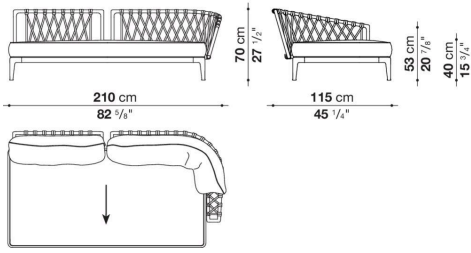

CE245S

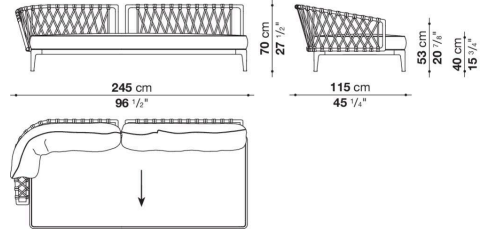

CE245D

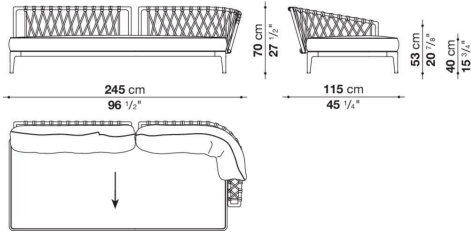

CE264TAS

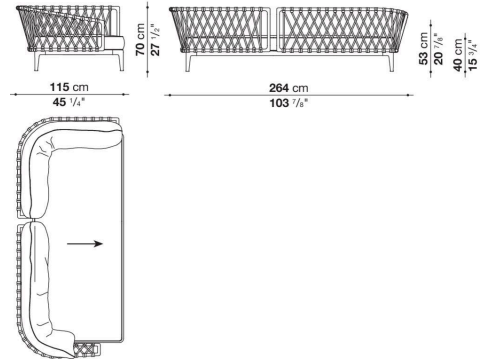

CE264TAD

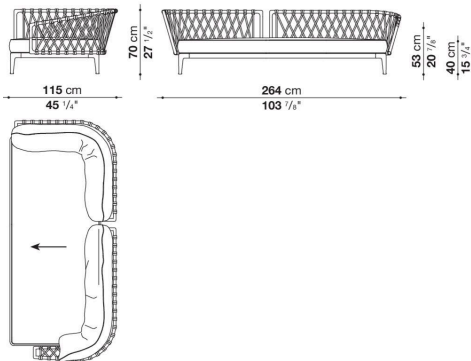

CE210AS

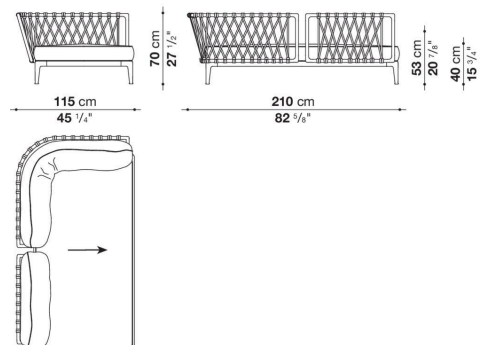

CE210AD

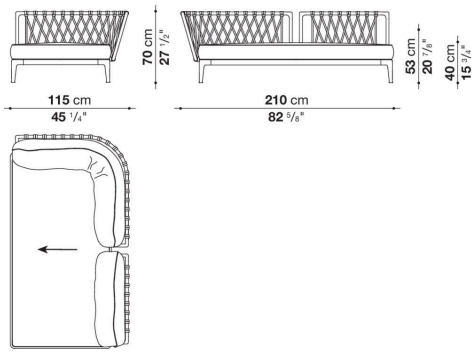

CE245AS

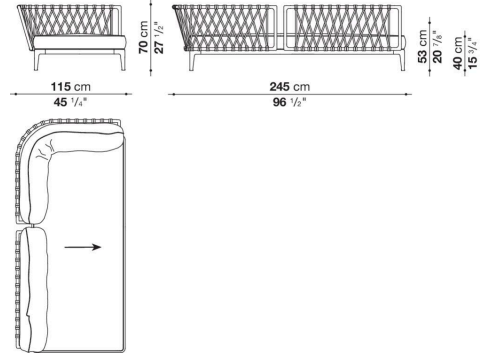

CE245AD

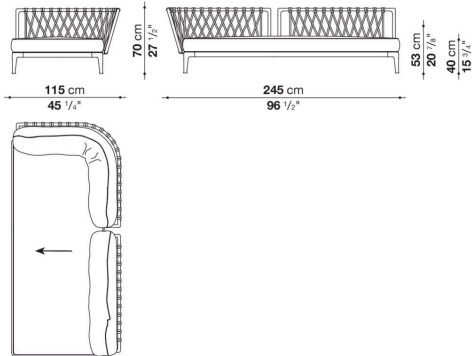

CE150L

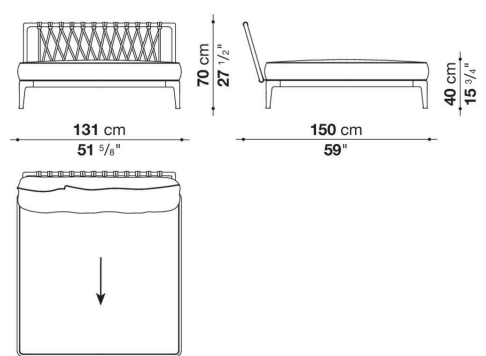

CE150LS_1

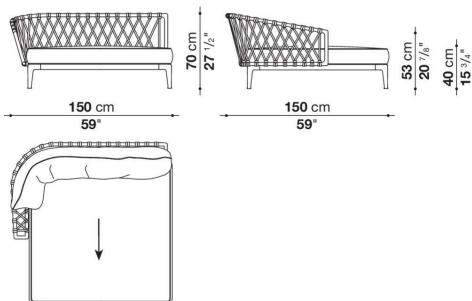

CE150LD_1

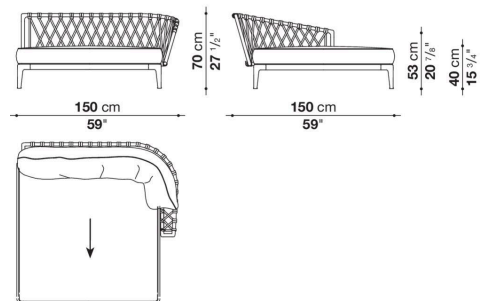

CE150LS_2

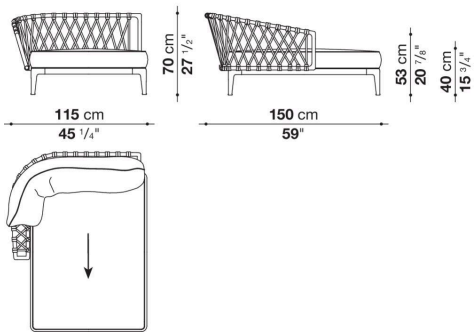

CE150LD_2

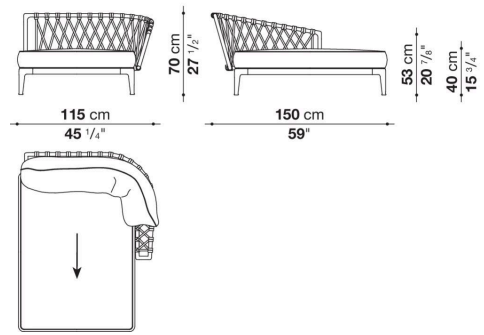

CE210LS

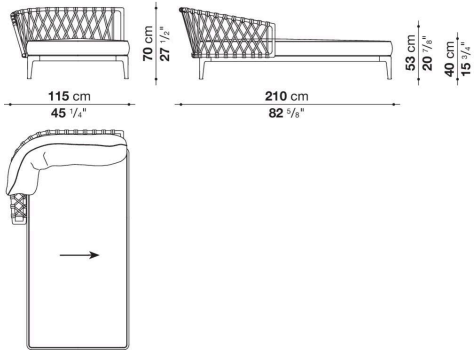

CE210LD

