

B&B Atoll

SOFAS

2018

Antonio Citterio



Description

B&B Atoll, das neue modulierbare Sofasystem von Antonio Citterio, dessen Name an die gleichnamigen Korallenriffe erinnert, ist Ausdruck einer ausgewogenen ästhetischen Form und eines entschiedenen modernen Stils von hoher Eleganz. Das System basiert auf drei Ausgangsplattformen in den Abmessungen 190 cm und 240 cm mit 90 cm Tiefe sowie 130 cm mit 140 cm Tiefe, die mit Arm- und Rückenlehnen auf verschiedene Weise kombiniert werden können: Rundsofas, Dormeusen, Eck-Endelemente, Einzelelemente oder mit Chaiselongue und Hocker kombinierbare Elemente. Sie haben eine leichte und schlichte Linienführung und liegen auf hohen Trägern aus Aluminiumdruckguss mit Metallprofilen auf, die die Linie zwischen dem Gestell und der Polsterung unterstreichen, in den zwei Ausführungen Hartzinn und schwarz verchromt. Für zusätzliche Akzente sorgt ein Stützelement, das nach Belieben verwendet werden kann: ein Rollenkissen in zwei Größen (65 cm und 90 cm), das mit Lederriemen an einem Gestell aus Aluminiumdruckguss befestigt ist. Dieses Accessoire kann beliebig als zusätzliche Stütze zwischen das Sitzkissen und das Untergestell eingefügt werden oder je nach Wahl als Arm- bzw. Rückenlehne. B&B Atoll erweist sich somit als ein absolut dynamischer Entwurf, der immer wieder neu zu unzähligen Sofasystemen zusammengestellt werden kann: von informalen Relax Möbeln bis hin zu formalen Kombinationen, nicht zuletzt durch die Verwendung zusätzlicher Rückenkissen.

Technical information

Innenrahmen

Stahlrohre und -profile

Innenrahmen Füllung

kalt elastischer Polyurethanschaum Bayfit®, Futter aus Polyesterfaser

Sitzkissen

geformtes Polyurethan verschiedener Dichten, sterilisierte Daunen, Futter aus Polyesterfaser

Rückenkissen

geformtes Polyurethan, sterilisierte Daunen

Nierenkissen (AT45_40)

Daunen, Typ mit Umrandung

Rollen

geformtes Polyurethan, Futter aus Polyesterfaser

Rollen-Träger

Aludruckguss

Rollen-Riemen

Stoff oder Leder

Traggestell

Aludruckguss

Gleiter

Kunststoff

Bezug

Stoff oder Leder

Technical drawings

ATR247S_3

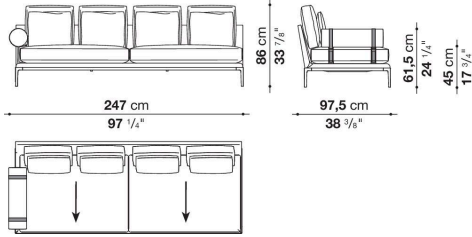

ATR247S_2

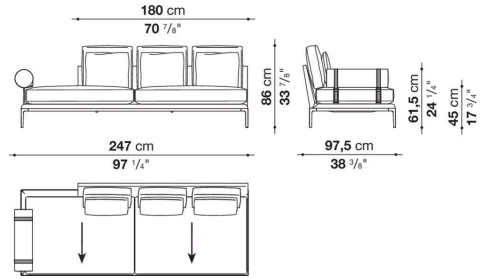

ATR247S_1

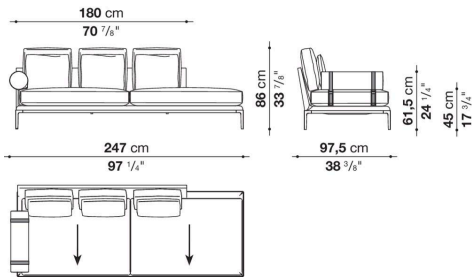

ATR247D_3

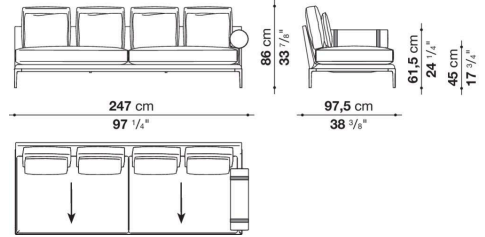

ATR247D_2

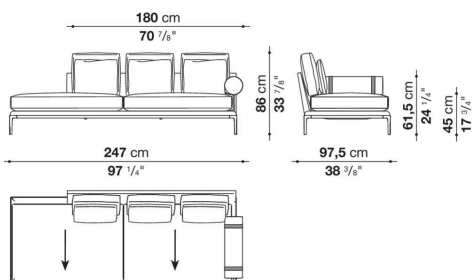

ATR247D_1

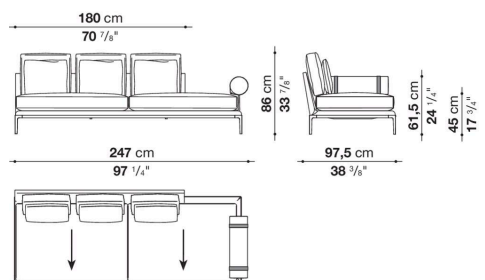

ATR197S_3

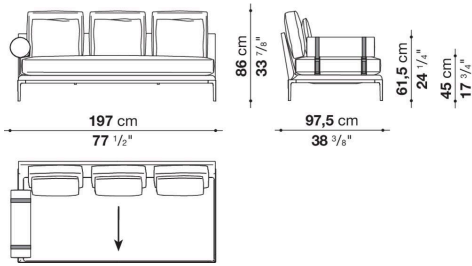

ATR197S_2

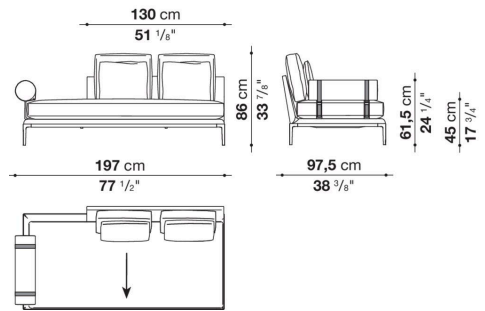

ATR197S_1

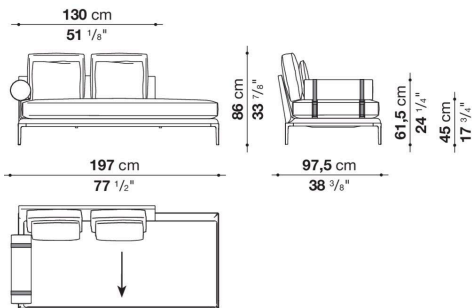

ATR197D_3

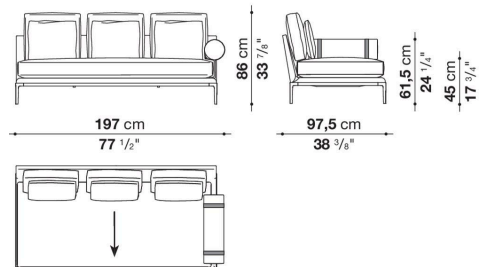

ATR197D_2

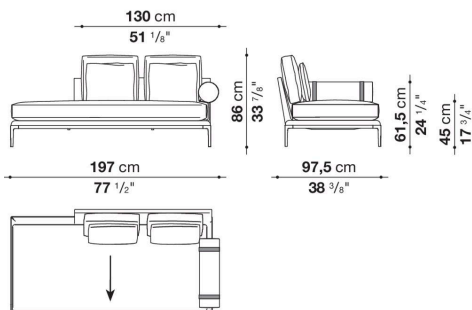

ATR197D_1

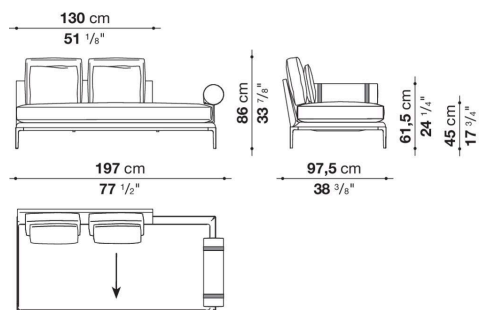

ATR137LS

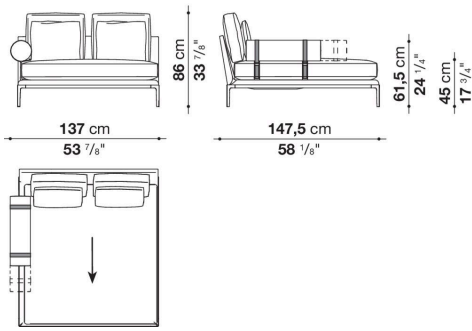

ATR137LD

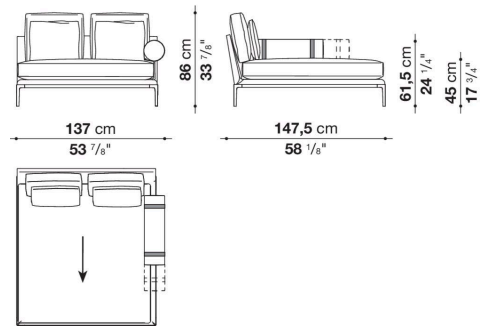

AT248TAS_3

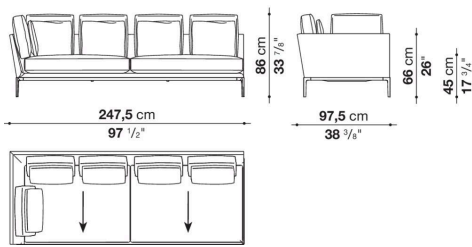

AT248TAS_2

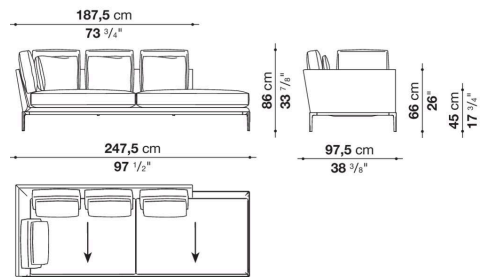

AT248TAS_1

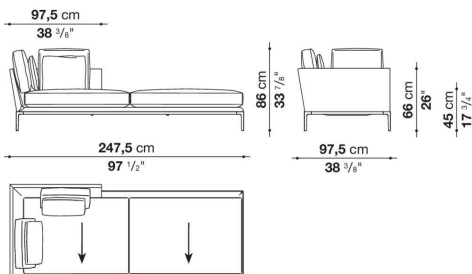

AT248TAD_3

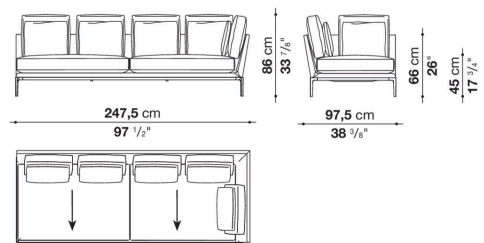

AT248TAD_2

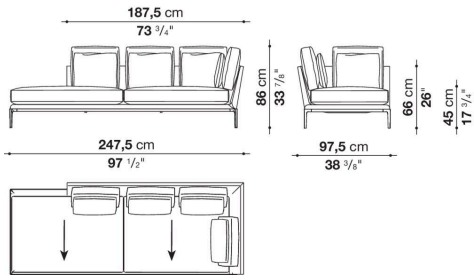

AT248S_3

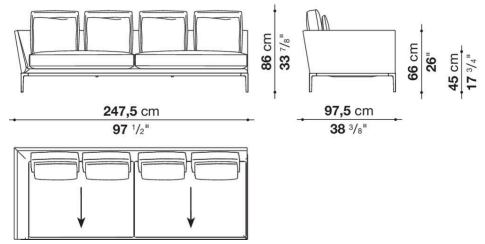

AT248TAD_1

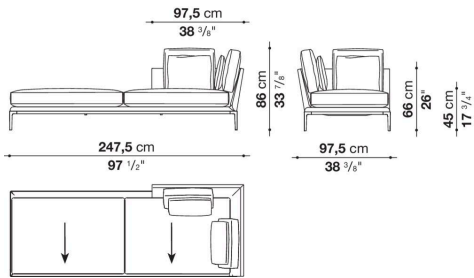

AT248S_2

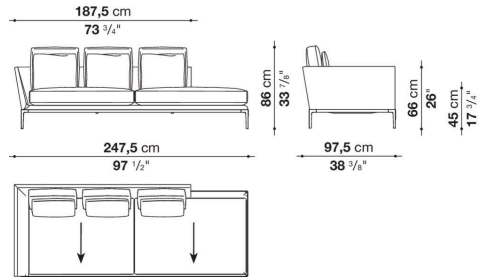

AT248S_1

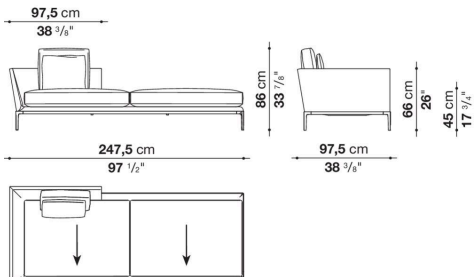

AT248LS_2

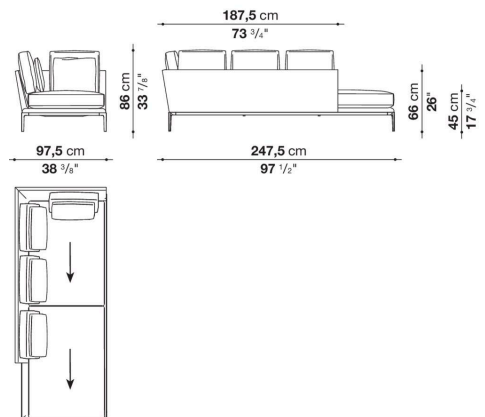

AT248LS_1

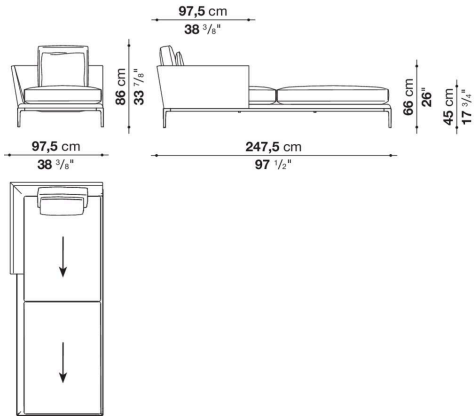

AT248LD_2

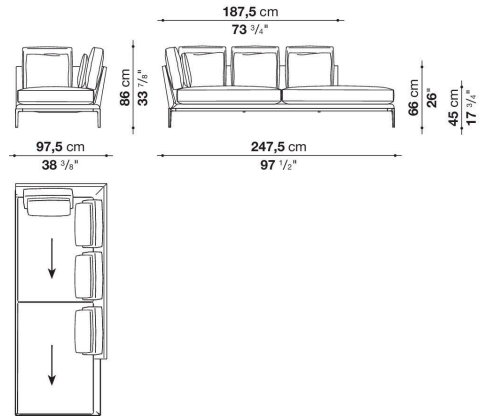

AT248LD_1

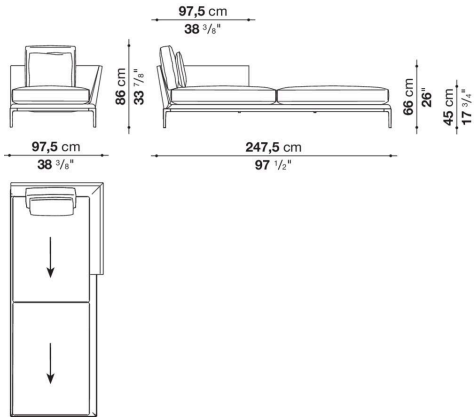

AT248D_3

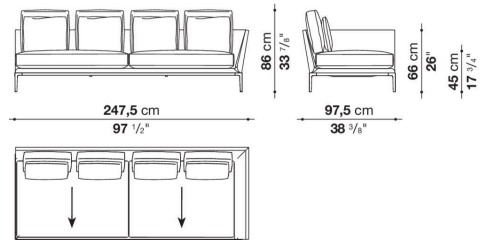

AT248D_2

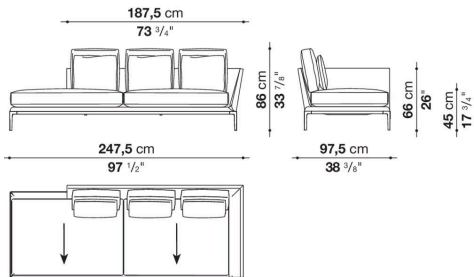

AT248D_1

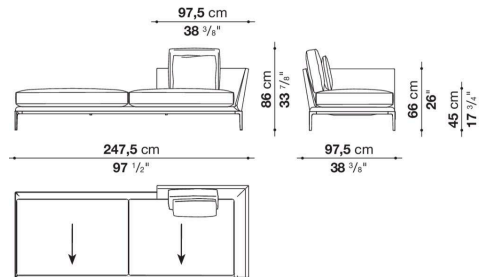

AT240PS

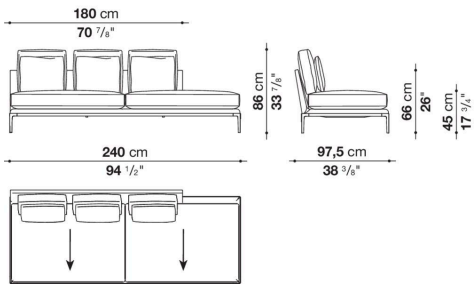

AT240PD

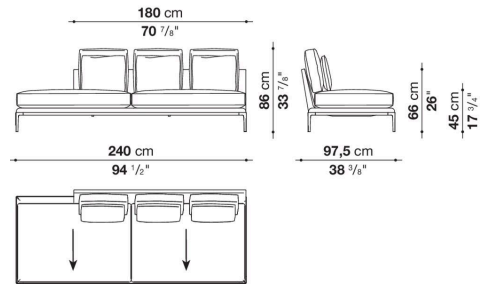

AT240C

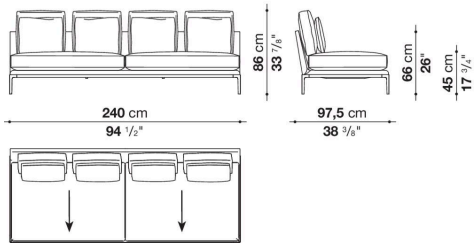

AT198TAS_2

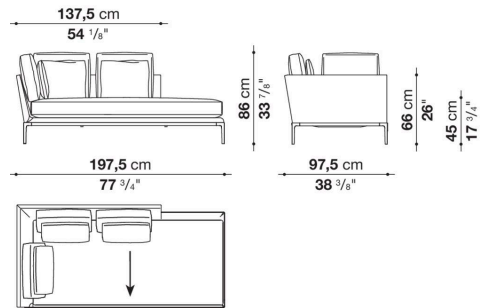

AT198TAS_3

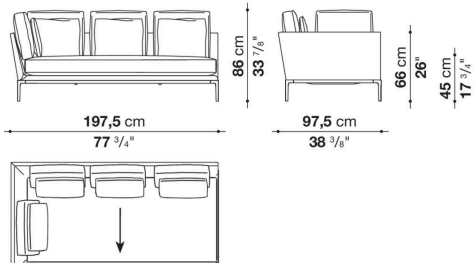

AT198TAS_1

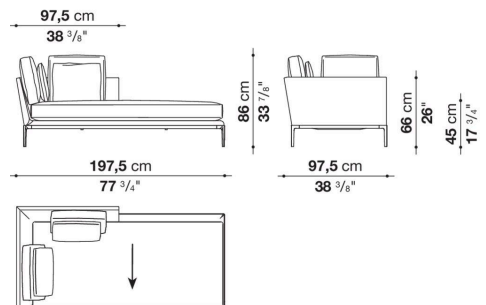

AT198TAD_2

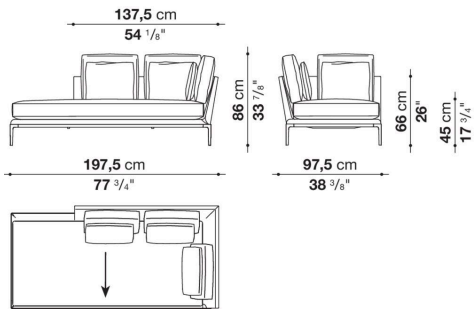

AT198TAD_3

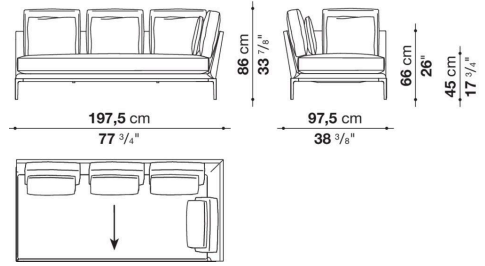

AT198TAD_1

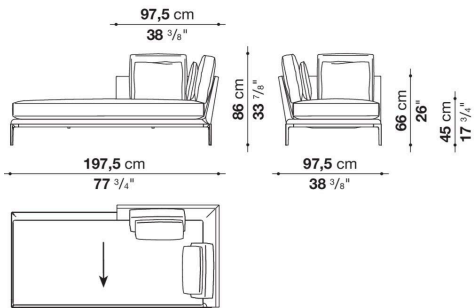

AT198S_3

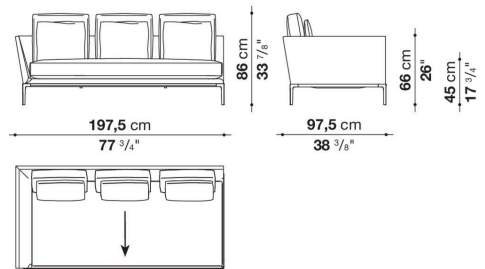

AT198S_2

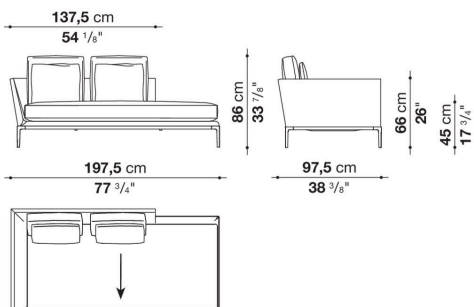

AT198S_1

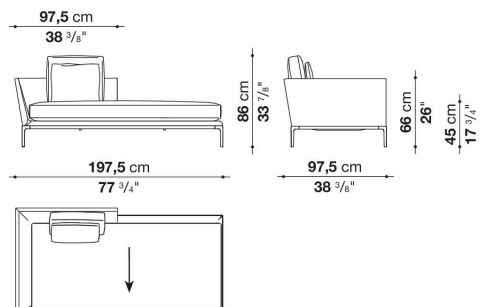

AT198LS_2

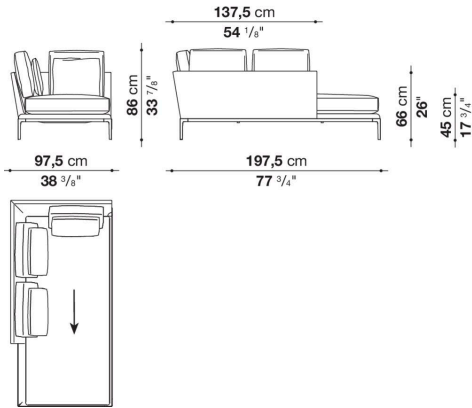

AT198LS_1

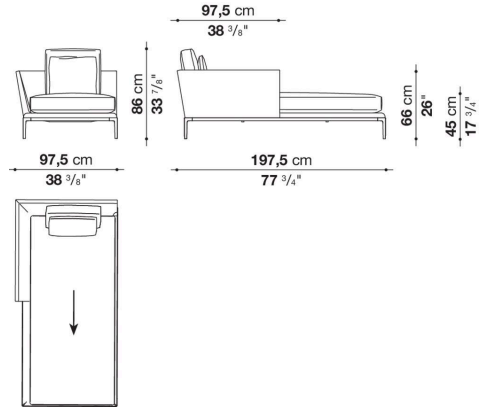

AT198LD_2

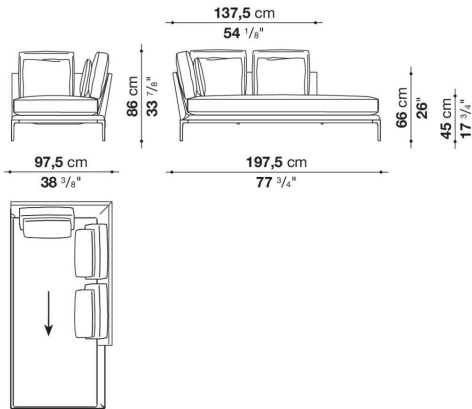

AT198LD_1

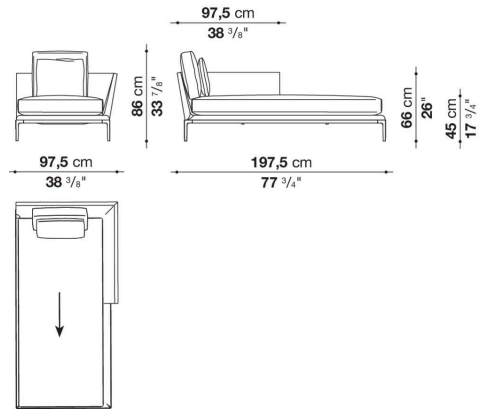

AT198D_3

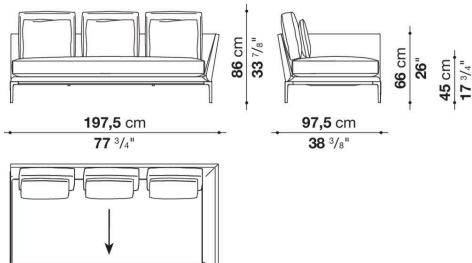

AT198D_2

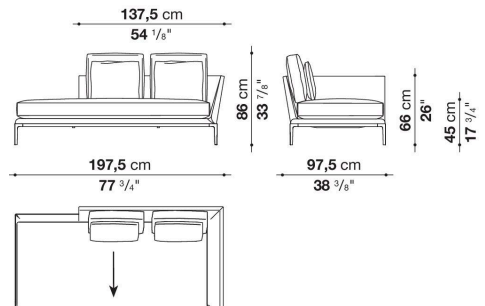

AT198D_1

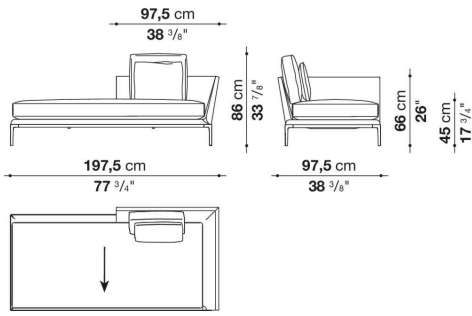

AT190C

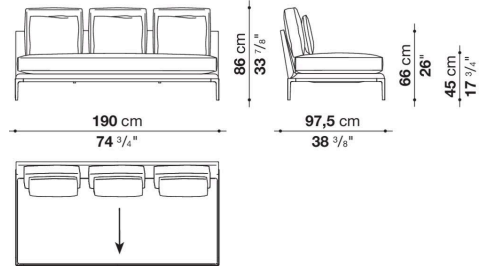

AT190PS

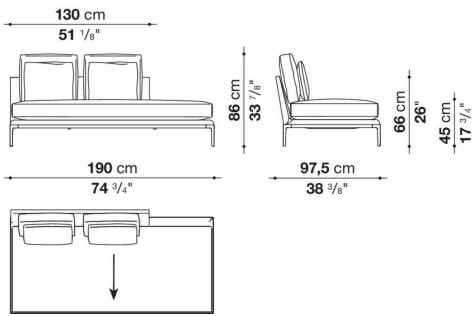

AT190PD

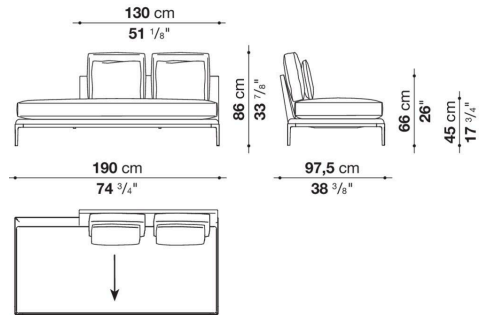

AT138LS

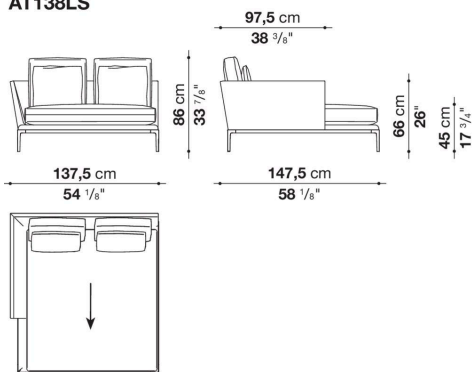

AT138LD

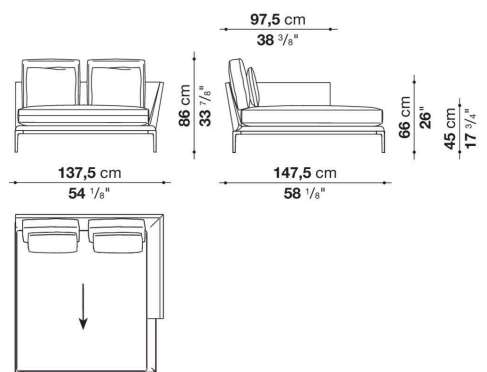

AT130L

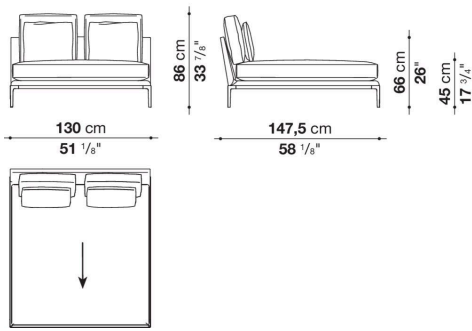

ATR240P

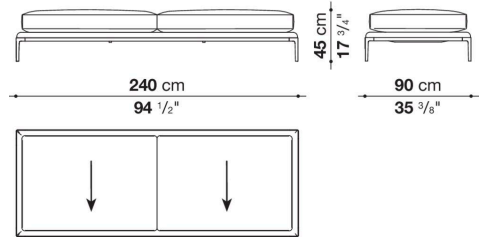

ATR190P

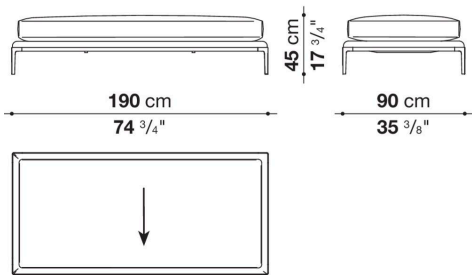

ATR130PS

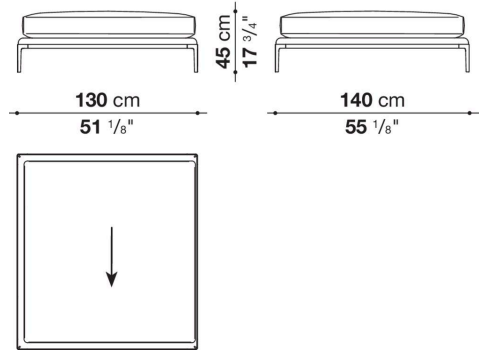

ATR130PD

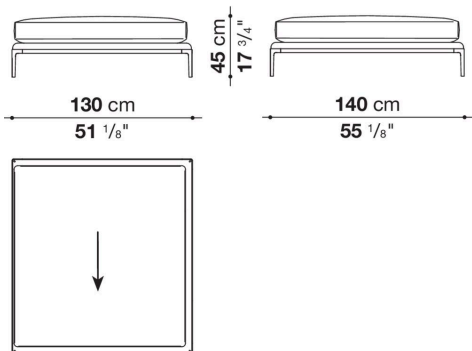

ATR130P

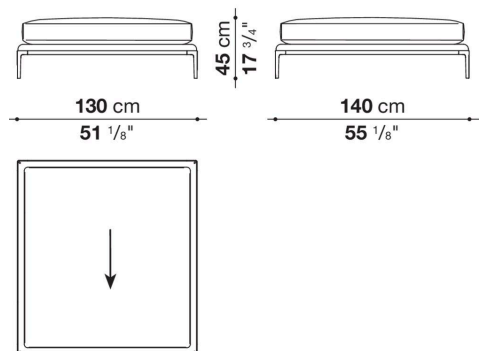

AT89PQF

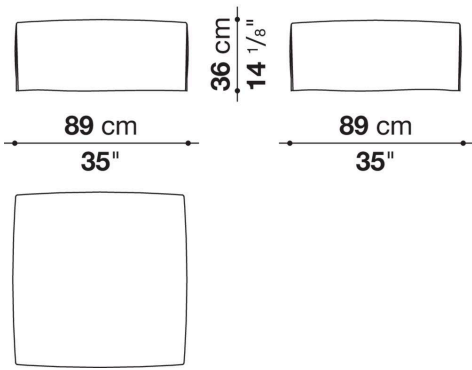

AT154DPF

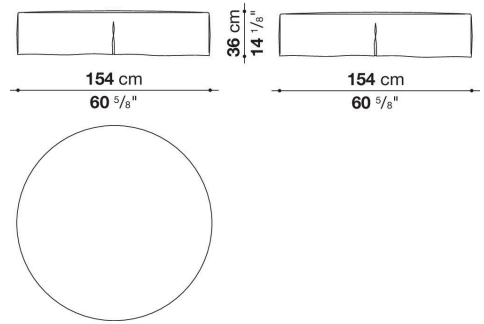

AT153PQF

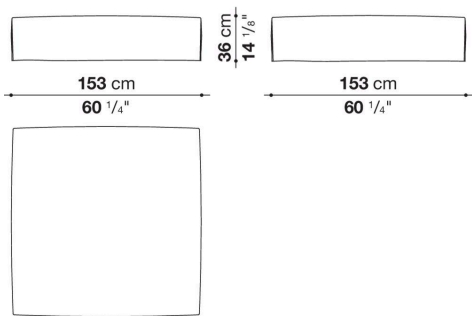

AT153PF_2

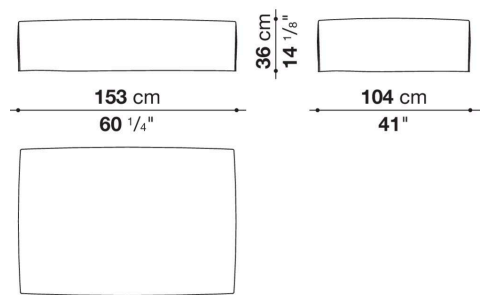

AT153PF_1

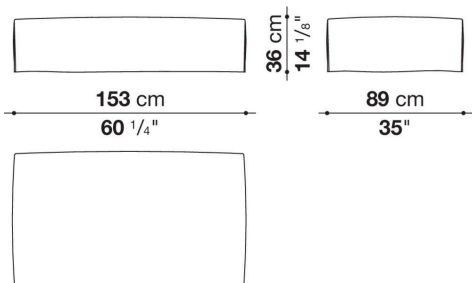

AT110DPF

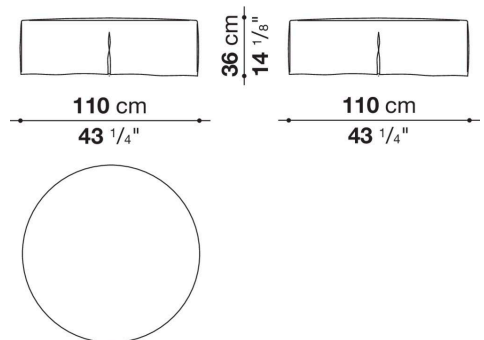

AT104PQF

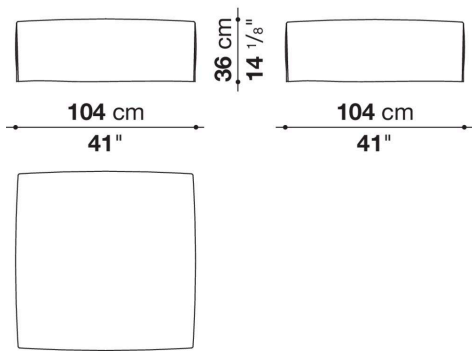

ATR254

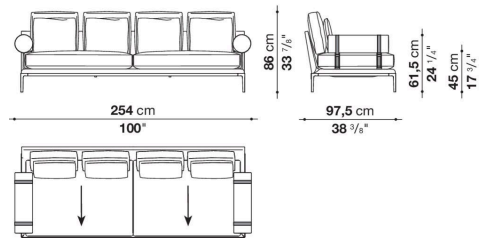

ATR204

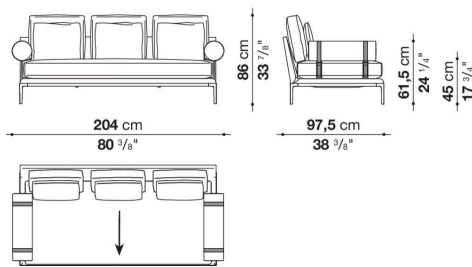

AT255AS

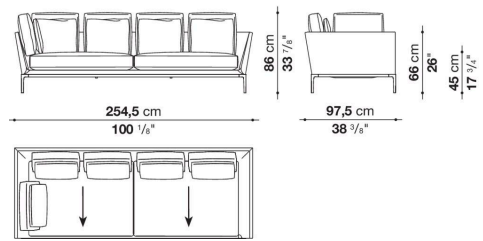

AT255AD

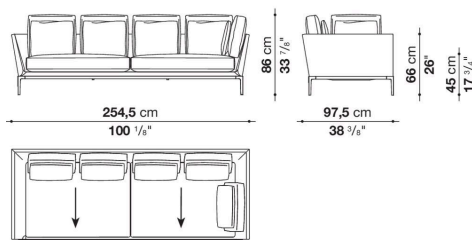

AT255

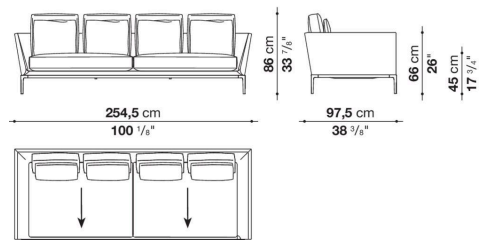

AT205AS

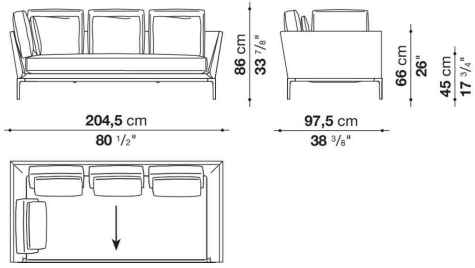

AT205AD

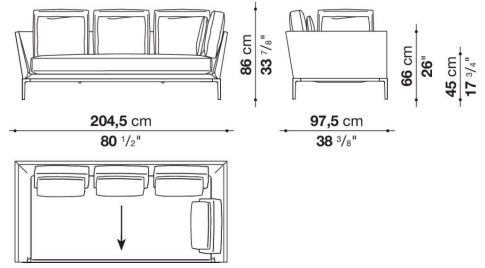

AT205

