

# Charles Large Carré

DIVANI

2024

Antonio Citterio



## Description

---

In the spirit of revamping the icons of our heritage collection, the Charles Large family is now adorned with a carré pattern that is carefully and wisely crafted with a very refined technique. The particular checkered workmanship of the seat cushion cover is particularly elaborate: the cutting of the upper surface of the carré cushions is carried out for each single square which is numbered during the cutting phase for identification and reassembled during the sewing phase where it is coupled with a textile ribbon (in the case of fabric) or with a leather profile (in the case of leather upholstery) first on the short sides (checkered/ribbon/checkered) and then on the long sides.

## Technical information

---

**Internal frame**

tubular steel and steel profiles

**Internal frame upholstery**

Bayfit® flexible cold shaped polyurethane foam, polyester fibre cover

**Seat cushion upholstery (home)**

shaped polyurethane of different density, sterilized down, polyester fibre cover

**Seat cushion upholstery (public spaces)**

shaped polyurethane of different density, polyester fibre, polyester fibre cover

**Back cushion (CH48\_C-CH72\_C)**

polyester fibre, cotton cover, box style typology

**Feet**

die-cast aluminium

**Ferrules**

thermoplastic material

**Cover**

fabric or leather (grosgrain ribbon)

# Technical drawings

**CHL270\_1Q**

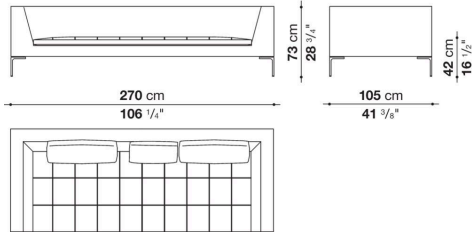

**CHL158S\_Q**

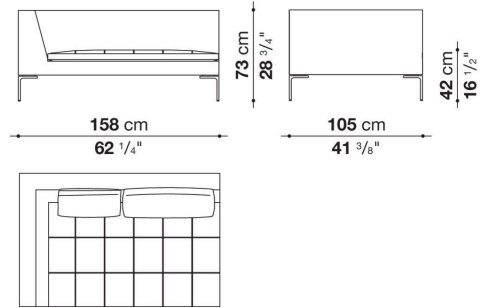

**CHL158D\_Q**

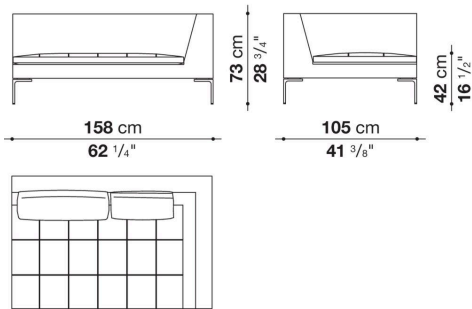

**CHL247S\_1Q**

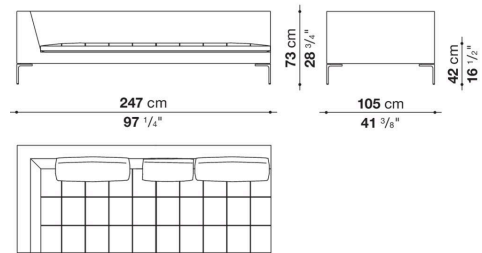

**CHL247D\_1Q**

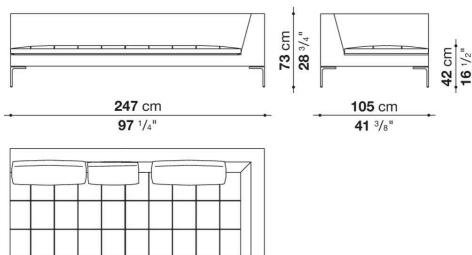

**CHL135LS\_Q**

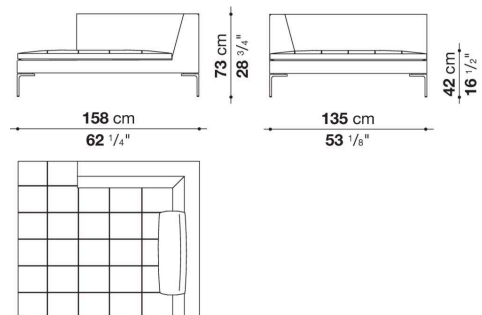

**CHL135LD\_Q**

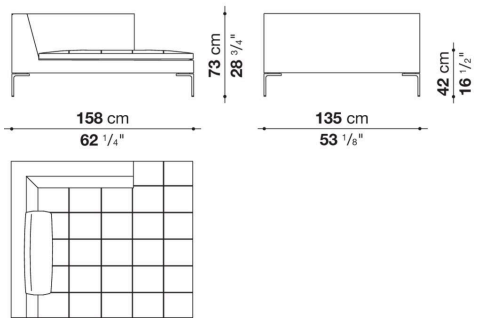

**CHL247LS\_1Q**

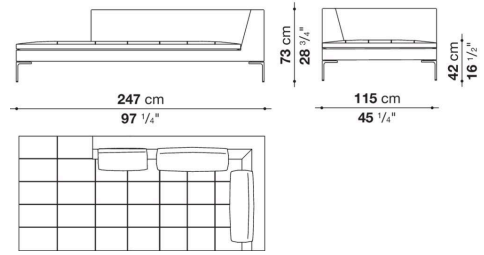

**CHL247LD\_1Q**

