Charles

DIVANI

1997

Antonio Citterio



Description

An icon of contemporary design, the Charles sofa stands out for its light image accentuated by the essential design of the die-cast aluminium feet in the shape of an inverted “L” which, together with the design of the armrest, the single seat cushion and the free back cushions, is the distinctive element of the line. The airy shape and simple profile make it, almost by contrast, extremely rich and innovative from a spatial standpoint: a system that encourages the creation of ever new compositions, from an in-line two- or three-seater sofa, to a sofa with chaise longue, to a corner sofa. Charles reveals a great formal elegance that goes well beyond the current times and fashions. A broad selection of elements satisfies any furnishing need, including the most personal desire for comfort. The cover is available either in fabric or in leather.

Technical information

Internal frame

tubular steel and steel profiles

Internal frame upholstery

Bayfit® flexible cold shaped polyurethane foam, polyester fibre cover

Internal frame upholstery (CHP-CH150P)

shaped polyurethane of different density, polyester fibre cover

Seat cushion upholstery (home)

shaped polyurethane of different density, sterilized down, polyester fibre cover

Seat cushion upholstery (public spaces)

shaped polyurethane of different density, polyester fibre, polyester fibre cover

Back cushion (CH48_C-CH72_C)

polyester fibre, box style typology

Feet

die-cast aluminium

Ferrules

thermoplastic material

Cover

fabric or leather

Technical drawings

CH228

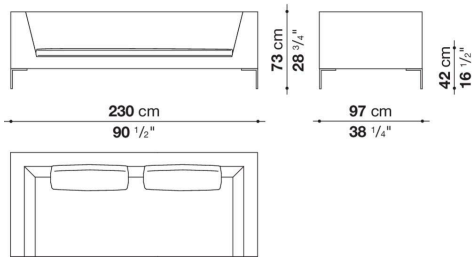

CH156C

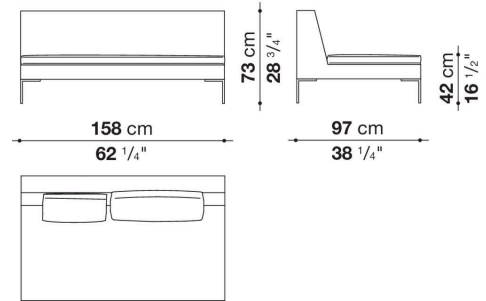

CH228C

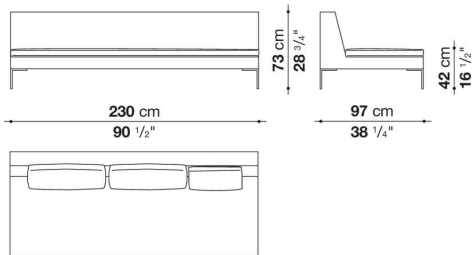

CH156S

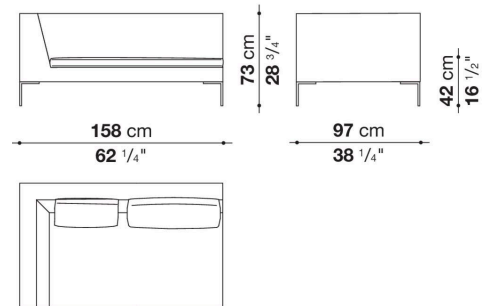

CH156D

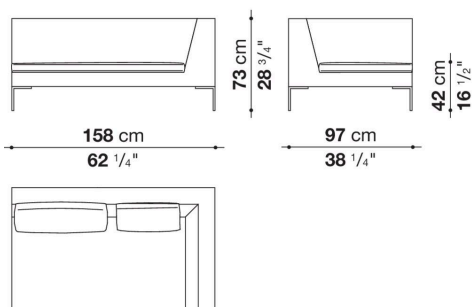

CH228S

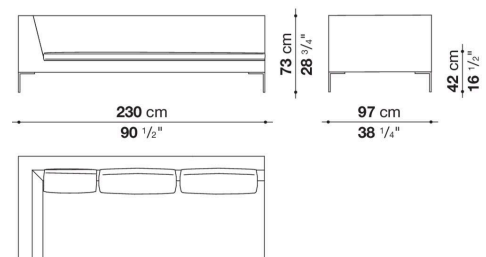

CH228D

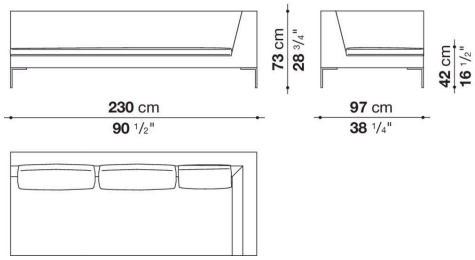

CH156TPS

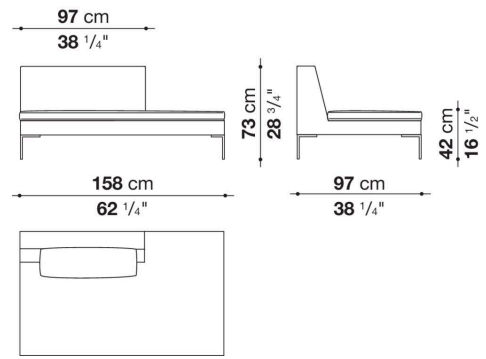

CH156TPD

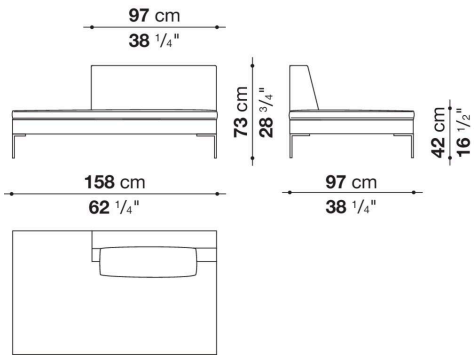

CH156LS

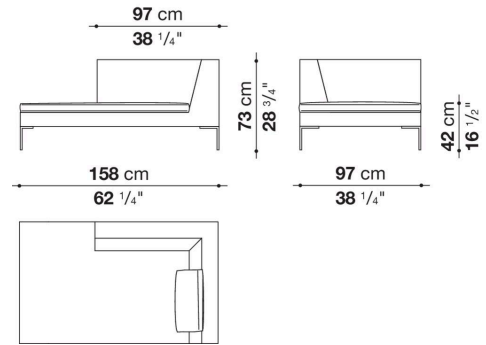

CH156LD

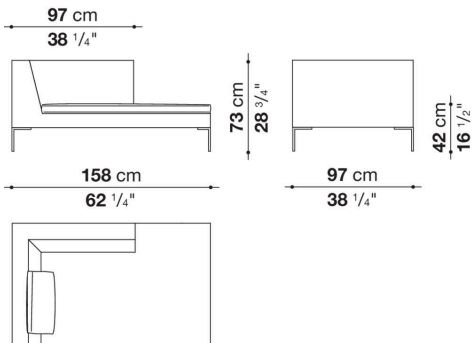

CH228LS

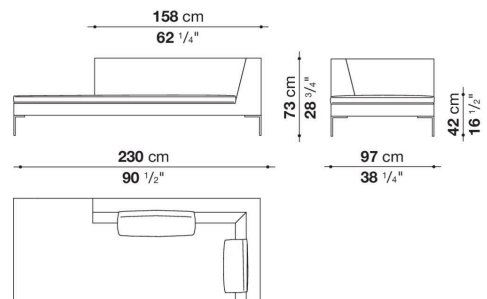

CH228LD

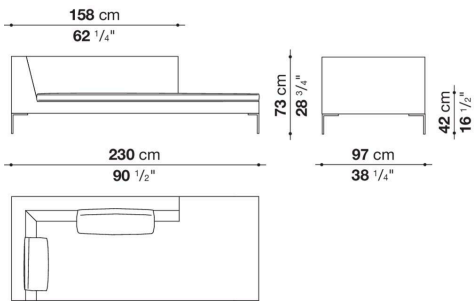

CH150P

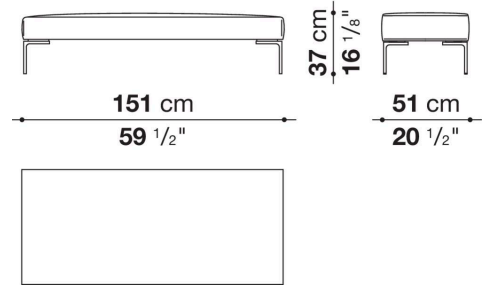

CHP

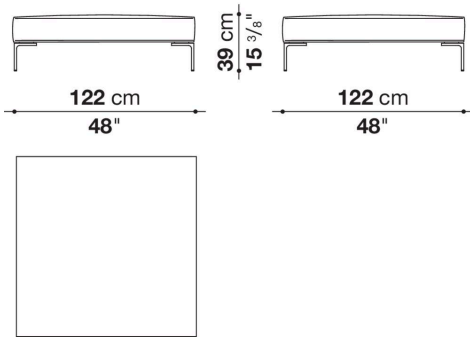

CH180L

