

# Hollow

POLTRONE

2006

Patricia Urquiola

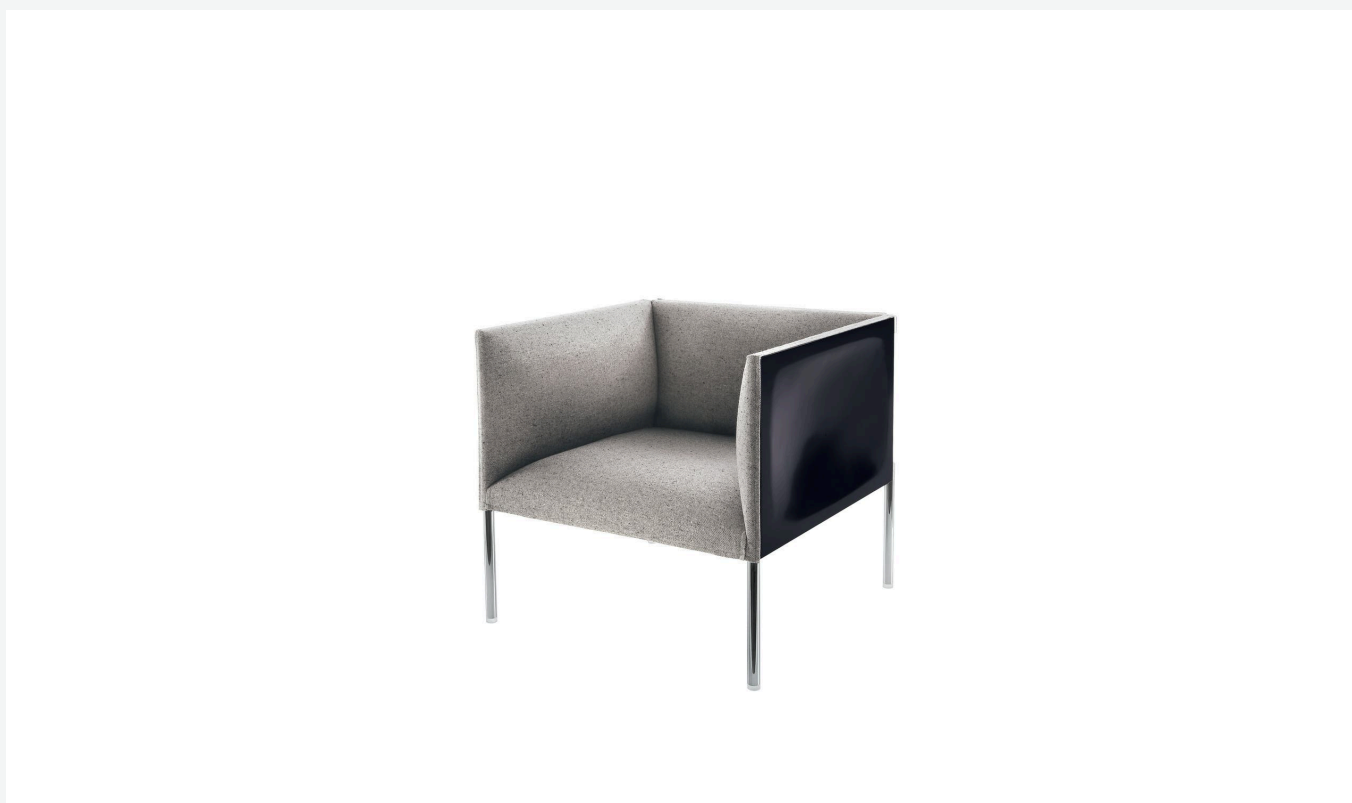

## Description

---

This project is the result of a group of modular panels of different sizes, which can be assembled through hinges to act as back and armrest and hold a soft seats. Blocked and supported by the legs, the entirely upholstered and lined panels display a concave plastic surface on the outside, which visually moves the elements and enhances their effect of lightness.

## Technical information

---

**Internal frame**

tubular steel and steel profiles

**Internal frame upholstery**

Bayfit® flexible cold shaped polyurethane foam, polyester fibre cover

**Shell**

plastic material or plastic material and leather

**Feet and joints**

steel

**Ferrules**

thermoplastic material

**Cover**

fabric or leather in limited categories

# Technical drawings

## HO71

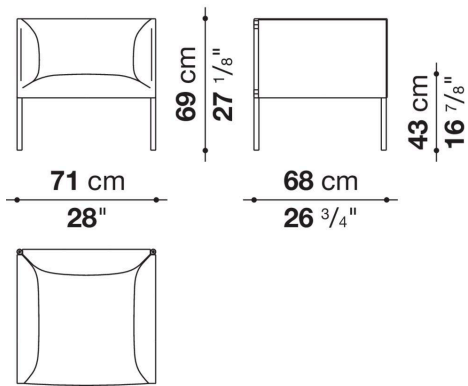

## HO80

